



**PERFORMANCE DATA SHEET
NEMA PREMIUM NR CAN NEMA 12 - 12**

Catalogue #: MQOP-78

HP	kW	Voltage	S.F. @ 60Hz	EFF.	P.F.	Frame	Design	L.R. Amps
100	74,60	230/460	1,15	95,0%	0,84	444T	B	725

60 Hz								Code	F.L. RPM
208	230	416	460	480	575	600			
/	234	/	117,00	/	/			G	1190

50 Hz								
FLA			S.F. @ 50Hz	Efficiency	Power Factor	Code	F.L. RPM	
190	380	415						
294,0	147		1,00	93,5%	0,820	E	985	

Wgt. Lbs	PH	Duty	Insul. Class	Amb.	Elevation	Temp. Rise° C
1320	3	Cont.	F	40°C	1000M (3,300 Ft)	< 80

% Efficiency		% Power Factor		Torque		Winding Resist. Ω	Safe Cold Start (Secs)
Full Load:	95,0%	Full Load:	0,84	Full Load Ft/Lbs	441,3		
3/4 Load:	94,5%	3/4 Load:	0,82	Locked Rotor %	150		
1/2 Load:	94,5%	1/2 Load:	0,75	Break Down %	245		

Rotor Inertia Wk2 Lb-Ft2	Max Load Inertia Wk2 Lb-Ft2	Shaft Material	Frame Material	DE Bracket Type	ODE Bracket Type	Enclosure	NEMA Rating	Lead Wire Size
80,68	1610	1045	Cast Iron	Cast Iron	Cast Iron	ODP	IP23	6AWG

Ball Bearings		Grease	Mount Type	Orientation	Paint	Sound Pressure @ 3FT	Sound Power
DE	ODE						
NU319	6318	Mobil PolyrexEm	Rigid	Horizontal	RAL6022	82	94

Inverter Duty, Motor meets MG1 parts 31.4.4.2	VFD SF	Constant Torque Range	Variable Torque Range	Constant HP RPM
	1,00	10:1	20:1	1800

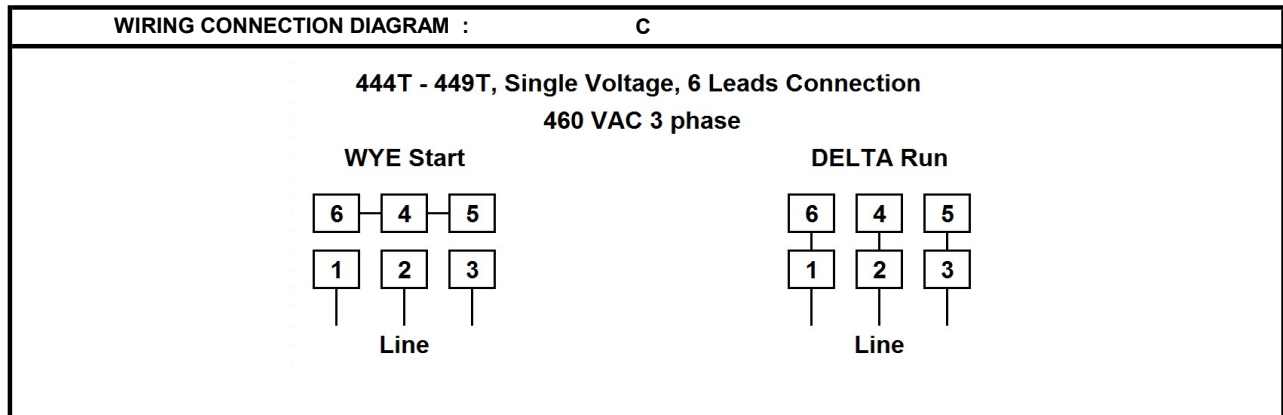

Date: 2023-12-13
 Customer: _____
 Contact: _____
 Submittee: J.C. Lavallée

Catalogue #: **MQOP-78**

NEMA PREMIUM NR CAN NEMA 12 - 12										
HP	VAC	RPM	Enclosure	Frame	Frequency	Design	Poles	LR Code Letter	Insulation Class	Temp. Rise °C
100	460	1190	ODP	444T	60 Hz	B	6	G	F	< 80
	0Hz	6Hz	15Hz	30Hz	45Hz	60 Hz	75Hz	90Hz	105Hz	120Hz
Amps	117	117	117	117	117	117	117	117	117	117
RPM	0	119	297,5	595	892,5	1190	1487,5	1785	2082,5	2380
Torq ft.lb	353,08	353,08	441,34	441,34	441,34	441,34	353,08	294,23	252,20	220,67
Peak Tq ft.lb	491,00	981,99	981,99	981,99	981,99	981,99	785,59	654,66	561,14	491,00
HP	0	8,0	25,0	50,0	75,0	100,0	100,0	100,0	100,0	100,0
	Locked Rotor	Pull-Up	Breakdown	Rated Load	Idle	Duty	S. F.	Ambient	Elevation	dBA @ 1M
Speed (RPM)	0,0	504	960	1190	1200	Continuous	1,15	40°C	3,300 ft	82
Current (Amps)	725,0	616,3	431,4	117,0	44,5	VFD Rating: Meets MG1 parts 31.4.4.2				
Torque (ft.-lbs)	662,0	496,5	1081,3	441,3	0,0	C.T.	10:1	V.T.	20:1	VFD SF 1.00

Motor Speed Data

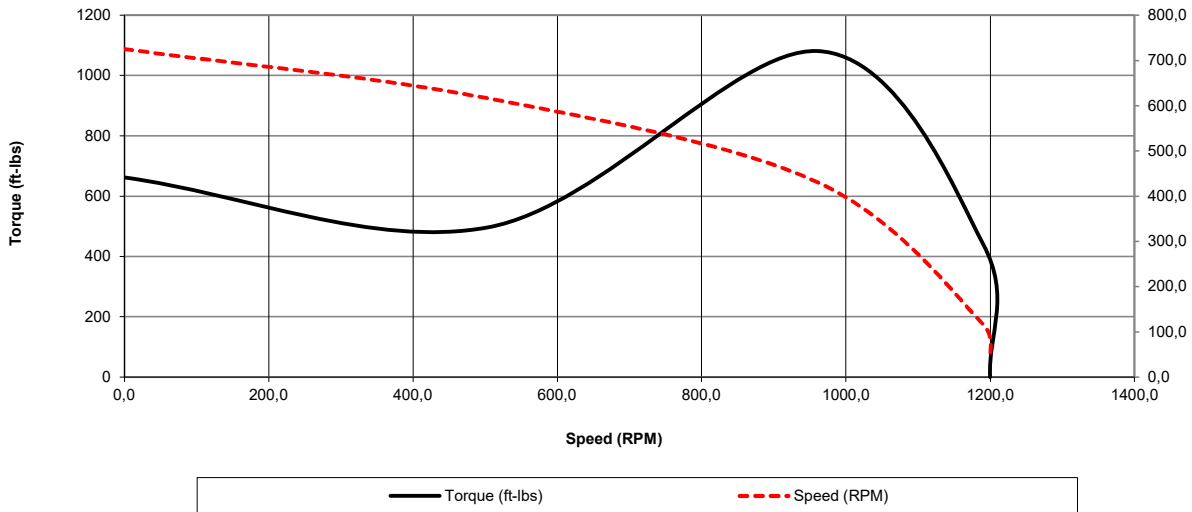

Motor Torque Capability vs RPM

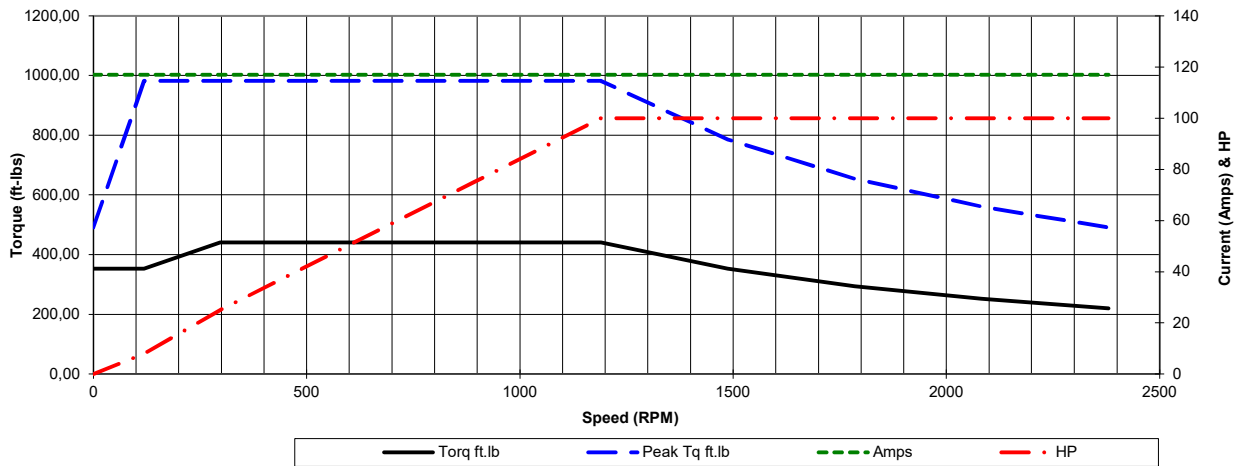



Date: 2023-12-13
 Customer: _____
 Contact: _____
 Submittee: J.C. Lavallée

Catalogue #: **MQOP-78**

NEMA PREMIUM NR CAN NEMA 12 - 12										
HP	VAC	RPM	Enclosure	Frame	Frequency	Design	Poles	LR Code Letter	Insulation Class	Temp. Rise °C
100	460	1190	ODP	444T	60 Hz	B	6	G	F	< 80
Load %	0%	25%	50%	75%	100%	125%	150%			
Amps	44,46	38,61	69,26	91,38	117,00	147,54	181,33			
Torq ft/lbs	0	109,65	219,75	330,31	441,34	552,84	664,81			
RPM	0	1197,5	1195	1192,5	1190	1187,5	1185			
Eff	0	93,27	94,50	94,50	95,00	93,51	93,14			
PF	0	65	75	82	84	84,84	83,16			
	Locked Rotor	Pull-Up	Breakdown	Rated Load	Idle	Duty	S. F.	Ambient	Elevation	dBa @ 1M
Speed (RPM)	0	504	960	1190	1200	Continuous	1,15	40°C	3,300 ft	82
Current (Amps)	725	616,3	431,4	117	44,46	VFD Rating: Meets MG1 parts 31.4.4.2				
Torque (ft-lbs)	662,02	496,51	1081,29	441,34	0,0	C.T.	10:1	V.T.	20:1	VFD SF 1.00

